



GT10000Ei ELECTRIC START INVERTER GENERATOR

9000W



Please ensure that you read this manual in full before using your machine and follow the maintenance and operation instructions carefully.

OPERATING INSTRUCTIONS

Contents

Introduction.....	3
Safety Information.....	4
Generator Safety Warnings.....	5
Know Your Generator	8
Generator Preparation.....	13
Generator Setup.....	17
Starting the Generator.....	19
Shutting Off the Generator.....	21
Maintenance.....	22
Transportation & Storage.....	27
Troubleshooting Guide.....	28
Warranty.....	29

Introduction

Welcome to the GT POWER family. By choosing GT POWER, a leader in reliable power solutions in New Zealand, you have secured a high-quality generator that adheres to stringent quality standards for superior performance. The GT5005Di is designed for a variety of applications including home use, camping, and emergency power situations, ensuring efficiency, reliability, and convenience. This manual will guide you through operation, maintenance, and safety information to help you enjoy many years of dependable service from your generator.

GT POWER is committed to customer satisfaction and supports this commitment with a comprehensive warranty program, demonstrating our confidence in the products we offer.



Environmental Protection

Recycle unwanted materials instead of disposing of them as waste. All tools, hoses and packaging should be sorted, taken to the local recycling centre and disposed of in an environmentally safe way.



Scope Of Product

This product is suited for home and camping, back-up power, rural and commercial applications.

Specifications

Model	GT10000Ei
Rate Output:	8500W
Max. Output:	9000W
Engine Type:	4-stroke, OHV, single cylinder with forced air cooling system
Starting Method:	Electric Start /Recoil
Power Outlets:	1x 32A, 1x 15A 230V 50Hz
Fuel Tank Capacity:	34L
Oil Type:	Unleaded 91 Petrol
Run Time:	16hrs @ 50% load
kVA:	11.25
Amps:	39.1A
Oil Capacity:	1.1L SAE30
Noise Level:	79dBA @ 50% Load
Dimensions (LxWxH):	655 x 634 x 752mm
Weight:	85kg

Safety Information

 **WARNING:** Before operating the generator, make sure to read all safety warnings and all instructions. Failure to follow the warnings and instructions may result in electric shock, fire or serious injury.

SAFETY INTRODUCTION

Safety is a combination of common sense, staying alert, and knowing how your tool works. This manual contains important information regarding the generator's potential safety concerns, as well as preparation, operation, and maintenance instructions. Before operating this generator, be sure to read and observe all warnings and instructions both on the generator labels and in this instruction manual. Failure to follow all instructions listed below may result in personal injury.

NOTE: The following safety information is not meant to cover all possible conditions and situations that may occur. We reserves the right to change this product and specifications at any time without prior notice.

SAVE THESE INSTRUCTIONS - Please keep this manual available to all users during the entire life of the tool. Review it frequently to maximize safety for both yourself and others.

SAFETY SYMBOLS

The purpose of following safety symbols is to attract your attention to possible dangers. The safety symbols, and their explanations, deserve your careful attention and understanding. The safety warnings do not by themselves eliminate any danger. The instructions or warnings they give are not substitutes for proper accident prevention measures.

 **DANGER:** indicates a hazard, which, if not avoided, will result in death or serious injury.

 **WARNING:** indicates a hazard, which, if not avoided, could result in death or serious injury.

 **CAUTION:** indicates a hazard, which, if not avoided, might result in minor or moderate injury.

CAUTION: when used without the alert symbol, indicates a situation that could result in damage to the machine.



WARNING!

HAZARDOUS KEEP NEW AND USED BATTERIES OUT OF REACH OF CHILDREN.

Never allow children to replace button batteries on any device. Swallowing or placing inside any part of the body may lead to severe or fatal injuries in as little as 2 hours or less due to chemical burns and potential perforation of the oesophagus.

If you suspect your child has swallowed a button battery or placed inside any part of the body, immediately call the POISONS INFORMATION CENTRE on 13 11 26 for prompt advice. If your child is having any difficulty breathing, contact 000. Dispose of used button/ coin batteries immediately and safely. A battery can still be dangerous even when it can no longer operate the device. Place sticky tape around both sides of the battery and dispose of it immediately out of reach of children in an outside bin or recycle safely.

Generator Safety Warnings

DANGER: CARBON MONOXIDE

Using a generator indoors **CAN KILL YOU IN MINUTES**. Generator exhaust fumes contains carbon monoxide (CO). This is a poison gas you cannot see or smell. If you can smell the generator exhaust, you are breathing CO. But even if you cannot smell the exhaust fumes, you could be breathing CO.





NEVER use a generator inside homes, garages, crawl spaces, or other partially enclosed areas. Deadly levels of carbon monoxide can build up in these areas. Using a fan or opening windows and doors does NOT supply enough fresh air. ONLY use a generator OUTSIDE and far away from windows, doors, and vents. These openings can pull in generator exhaust fumes.

Even if you use a generator correctly, CO may leak into the home. ALWAYS use a battery-powered or battery-backup CO alarm in the home. If you start to feel sick, dizzy, or weak after the generator has been running, move to fresh air RIGHT AWAY. See a doctor. You may have carbon monoxide poisoning.

 **WARNING: RISK OF EXPLOSION. HIGHLY FLAMMABLE:** This generator may emit highly flammable and explosive petrol vapors, which can cause severe burns or even death, if ignited. A nearby open flame can lead to explosion even if not directly in contact with petrol.

- Do not operate near open flame, heat, or any other ignition source. Do not smoke near generator.
- Always operate on a firm, level surface.
- Always turn generator off before refueling. Allow generator to cool for at least 2 minutes before removing fuel cap. Loosen cap slowly to relieve pressure in tank.
- Do not overfill fuel tank. petrol may expand during operation. Do not fill to the top of the tank. Allow for expansion. Always check for spilled fuel before operating.
- If fuel spills, move the generator at least 9M away from the spill and wipe clean any spilled fuel before starting the engine.
- Empty fuel tank before storing or transporting the generator.

 **WARNING:** If this generator is used as a supply for a BUILDING'S WIRING SYSTEM, the generator MUST be installed by a qualified electrician and connected to a transfer switch as a separately derived system in accordance with all applicable laws and electrical codes and the National Electrical Code. The generator shall be connected to a transfer switch that switches all conductors excluding the equipment grounding conductor. The frame of the generator shall be connected to an approved grounding electrode.

 **WARNING:** Do not let comfort or familiarity with the product replace strict adherence to product safety rules. Failure to follow the safety instructions may result in serious personal injury.

OPERATING ENVIRONMENT

1. Using a generator indoors can kill you in minutes. Only use a generator OUTSIDE and far away from windows, doors and vents.
2. Do not smoke near the generator.
3. Do not operate near open flame, heat, or flammable materials. This generator may emit highly flammable and explosive petrol vapors, which can cause severe burns or even death if ignited. A nearby open flame can lead to an explosion even if it isn't directly in contact with petrol.
4. Do not expose the generator to rainy or wet conditions; doing so significantly increases the risk of electrical shock. Never handle the generator, electronic devices, or any cord while standing in water, while bare-foot, or when hands or feet are wet.
5. Always operate the generator on a dry, firm, level surface.
6. The generator should have at least 1.5M of clearance from buildings or other equipment during operation.
7. Do not allow children or non-qualified persons to operate the generator.

GENERATOR PREPARATION

1. Always ground the generator before using it to maximize safety (see "GROUND THE GENERATOR" section.)
2. Do not overfill fuel tank, as petrol may expand during operation. Do not fill to the very top of the tank. Leave room for expansion. Always check for spilled fuel before operating.
3. If any part of the generator, electrical device or power cord is broken, damaged, or defective, make sure it is repaired or replaced before operation. Service should only be performed by a qualified technician. Do not use receptacles or cords that show signs of damage, such as broken or cracked insulation.
4. If connecting the generator to a building's electrical system for standby power, you **MUST** consult a qualified electrician and install a transfer switch. Such connections must comply with local electrical laws and codes. Failure to comply can create a back-feed, which may result in serious injury or death to utility workers.
5. Never modify the generator in any way. Modifying or using the machine for any other purpose for which it is not designed may result in serious injuries, machine damage and voiding of the warranty

GENERATOR OPERATION

1. Only use the generator for its intended purposes. Modifying or using the generator for operations for which it was not designed may cause hazards and personal injury.
2. Do not touch bare wires or receptacles (outlets).
3. Do not exceed the wattage capacity of the generator by plugging in more electrical devices than the unit can handle. This could damage the generator and/or connected electrical devices. Check the operating voltage and frequency requirements of all electrical devices prior to plugging them into the generator.
4. Allow generator to run for several minutes before connecting electrical devices. Do not start or stop engine with electrical devices plugged in to the receptacles. Failure to do so could damage the generator and / or connected electrical devices.
5. Do not turn ON electrical devices until after they are connected to the generator.
6. Generators vibrate in normal use. During and after the use of the generator, inspect both the generator as well as extension and power supply cords for damage resulting from vibration.
7. Do not touch HOT PARTS. This generator produces heat when running. Temperatures near exhaust can exceed 65°C. Allow generator to cool down after use before touching engine or areas of the generator that become hot during use.
8. Turn off all connected electrical devices before stopping the generator.
9. Always turn generator off before refueling. Allow generator to cool for at least 2 minutes before removing fuel cap. Loosen cap slowly to relieve pressure in tank.
10. Turn the engine switch to "OFF" position when the engine is not running.
11. Empty fuel tank before storing or transporting the generator. Do not store generator or petrol near furnaces, water heaters, or any other appliances that produce heat or have automatic ignitions. Store the generator and fuel away from sparks, open flames, pilot lights, heat and other sources of ignition.
12. Always wash hands after handling generator.

CAUTION: Misuse of this generator can damage it or shorten its lifespan.

TO MAXIMIZE THE LIFESPAN OF YOUR GENERATOR:

We recommend running your generator at least once a month for 20 to 30 minutes. Start the generator according to the instructions and plug a small load in to make sure the outlet is producing electricity.

Know Your Generator

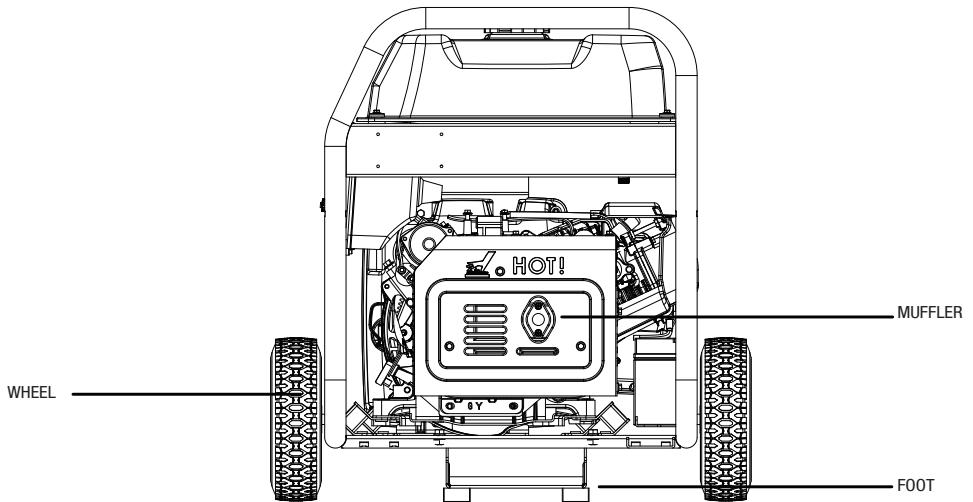
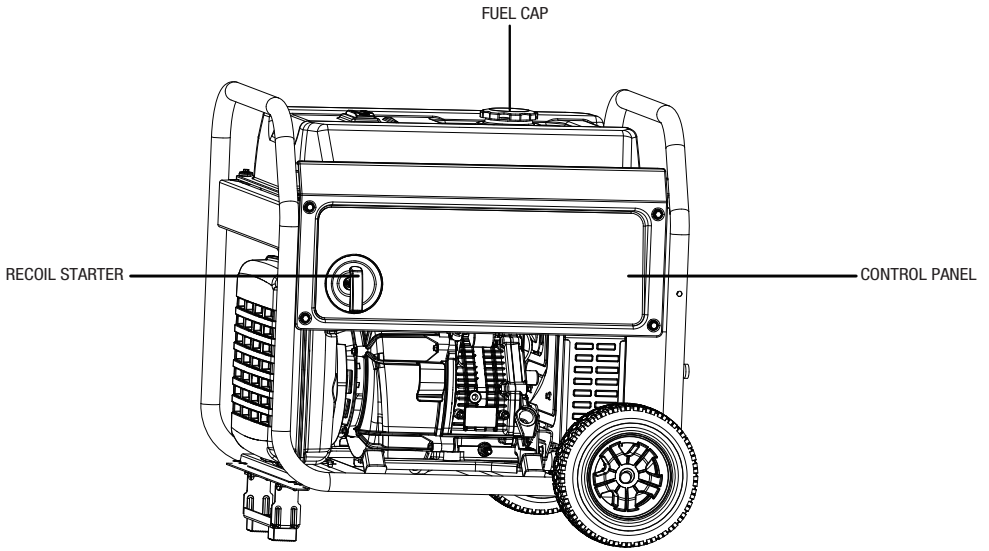

CONTROL PANEL

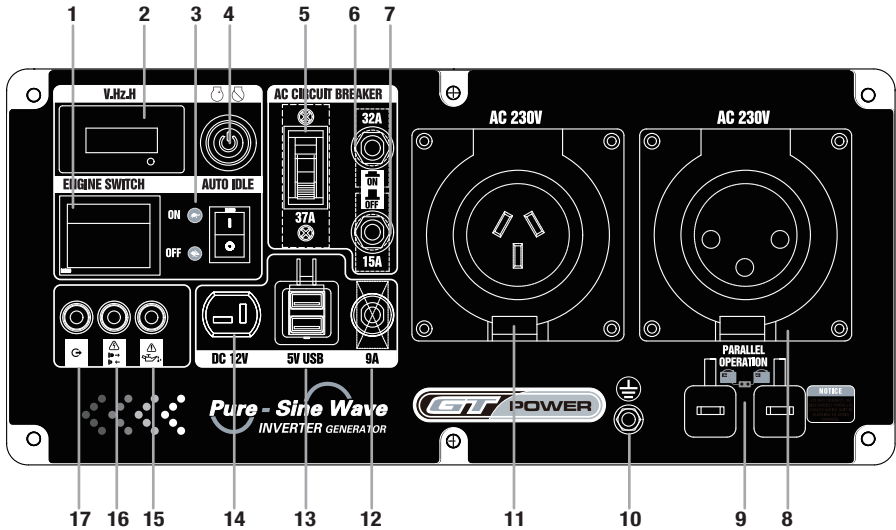

- | | |
|------------------------------|------------------------|
| 1.ENGINE SWITCH | 11.GROUNDING NUT |
| 2.V.HZ.H DISPLAY | 12.AC 240V SOCKET |
| 3.ENGINE-START/STOP SWITCH | 13.AC 240V SOCKET |
| 4.LOW IDLE | 14.RCD |
| 5.TWO WIRE CONTROL SWITCH | 15.CIRCUIT BREAKER 37A |
| 6.TWO WIRE CONTROL CONNECTOR | 16.LOW OIL ALARM |
| 7.CIRCUIT PROTECTOR 15A | 17.OVER LOAD ALARM |
| 8.CIRCUIT PROTECTOR 15A | 18.OUTPUT INDICATOR |
| 9.CIRCUIT PROTECTOR 32A | 19.RECOIL STARTER |
| 10.AC 240V SOCKET | |

LOW IDLE

This generator is equipped with an LOW IDLE Switch. Engaging this switch allows the system to regulate the engine speed and automatically adjust its fuel consumption to match the required load. When the electrical load changes, the generator engine will automatically speed up and slow down as needed. This reduces fuel consumption and noise levels, while extending runtime and engine's lifespan.

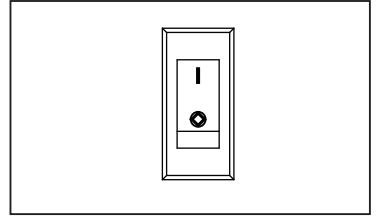

Keep this switch engaged **ONLY** when the power load requirement is **LESS THAN 75%** of the rated watts. Do not engage the switch when the total load is more than 75% of the rated watts. The generator engine must run at full speed to supply power for anything over 75% of the rated watts.

CIRCUIT BREAKERS

The circuit breakers protect the individual AC and DC circuits. The AC circuit breaker will activate when the AC outlets exceed. The DC circuit breaker will activate when the DC 12V and USB outlets exceed. When the circuit breaker activates, turn off and disconnect the device from its respective outlet, and press the circuit breaker to reset.

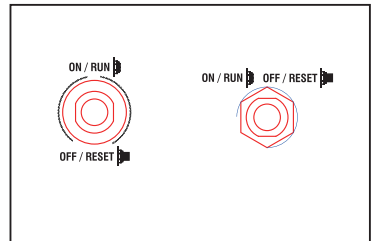

CONNECTING ELECTRICAL DEVICES

CAUTION: Before connecting devices, become familiar with the markings on the control panel before connecting electrical devices.

Follow the steps below to properly connect your device(s) to the generator:

1. Before connecting electrical devices, allow the generator to run for a few minutes to stabilize the speed and voltage output.
2. Select the device with the highest wattage, and make sure it is turned off. Plug the device into the generator and then turn the device on. Allow the engine to stabilize.
3. Repeat step 2 to plug in each additional device. **DO NOT** attempt to plug in or start multiple devices at the same time.

GENERATOR CAPACITY

Make sure the generator can supply enough running (rated) and starting (max.) watts for the items you will power at the same time. Follow these simple steps.

1. Select the items you will power at the same time.
2. Total the running (rated) watts of these items. This is the amount of power the generator must produce to keep the items running.
3. Estimate how many starting (max.) watts you will need. Starting wattage is the short burst of power needed to start electric motor-driven tools or appliances such as a circular saw or refrigerator. Because not all motors start at the same time, total starting (max.) watts can be estimated by adding only the item(s) with the highest additional starting (max.) to the total rated watts.

Example:

Tool or Appliance	Running Watts*	Additional Starting Watts*
Refrigerator	700	1350
Portable Fan	40	120
Laptop	250	250
46 in. Flat Panel Television	190	190
Light (75 Watts)	75	75
	1255 Total Running Watts	1350 Highest Starting Watts
	Total Running Watts	1255
	Highest Starting Watts	+ 1350
	Total Starting Watts Needed	2605

To prolong the life of the generator and attached devices, it is important to take care when adding electrical loads to the generator. There should be nothing connected to the generator outlets before starting its engine. The correct and safe way to manage generator power is to sequentially add loads as follows:

1. With nothing connected to the generator, start the engine as described later in this manual.
2. Plug in and turn on the first load, preferably the largest load you have.
3. Permit the generator output to stabilize (engine runs smoothly and attached device operates properly).
4. Plug in and turn on the next load.
5. Again, permit the generator to stabilize.
6. Repeat steps 4 and 5 for each additional load.

Never add more loads than the generator capacity. Take special care to consider surge loads in generator capacity as previously described.

NOTICE:

Do not overload the generator's capacity. Exceeding the generator's wattage/ampere capacity may damage the generator and/or electrical devices connected to it.

The chart below serves as a reference for the estimated wattage requirements of common electrical devices. However, do not solely rely on this chart - all electronics and appliances are built differently. Always check the wattage listed on the electrical device before consulting this chart.

Tool or Appliance	Rated (Running) Watts	Surge (Starting) Watts
Hot plate	2500	0
Electric stove (each element)	1500-2800	0
Saw - circular	1500	1500
Window air conditioner	1200	1800
Saw - miter	1200	1200
Microwave	1000	0
Well water pump	1000	1000
Sump pump	800	1200
Refrigerator freezer	800	1200
Furnace blower	800	1300
Computer	800	0
Electric drill	600	900
Television	500	0
Stereo	400	0
Box fan	300	600
Security system	180	0
Common light bulb	75	0

Generator Preparation

The following section describes the necessary steps to prepare the generator for use. Failure to perform these steps properly can damage the generator or shorten its life.

STEP 1 - ADD/CHECK OIL

The generator is shipped without oil. User must add the proper amount of oil before operating the generator for the first time. The oil capacity of the engine crankcase is **1.2 L**.

To add oil, follow these steps:

1. Place the generator on a level surface. Make sure the engine is OFF before adding or checking oil.

CAUTION: Keep the generator level! Tilting the generator to assist in filling will cause oil to flow into the wrong areas of the engine and cause damage.

2. Unscrew the oil access cover knob, and remove the cover from the side panel. Unscrew the oil dipstick from the engine.

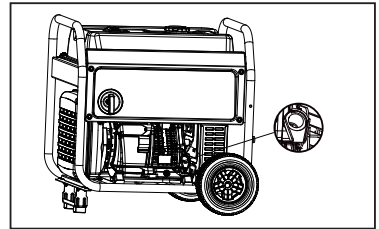

3. Using an oil funnel or appropriate dispenser, slowly add oil into the oil fill, being careful not to overfill the unit. Fill the crankcase to the upper fill line so you can visually see the oil coming halfway up the oil fill threads.

4. Reinstall the oil dipstick and firmly tighten it. Wipe clean any spilled oil.

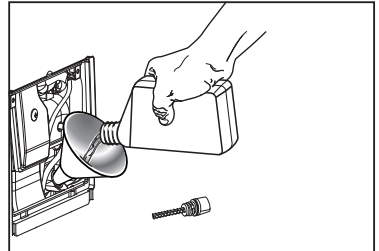

5. Reinstall the oil access cover. Turn the oil access cover knob to the locked position to secure the cover in place.

NOTE: Used engine oil should be disposed of at an approved disposal site. See local retailer for more information.

Recommended Oil Type: 10W-30

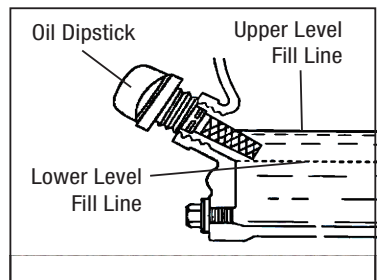
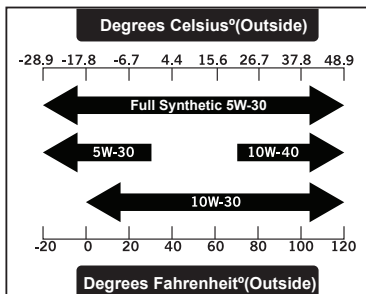

For subsequent operation, the oil level should be checked before each use, or after every 8 hours of operation. The generator is equipped with a low-oil sensor and will NOT start without a sufficient amount of oil.

To check oil level (before every subsequent start):

Place the generator on a level surface. Make sure the engine is OFF before adding or checking oil.

1. Open the oil access cover. Remove and wipe the dipstick with a clean rag.
2. Insert the dipstick into the oil fill without screwing it in. Remove the dipstick to check the oil mark.

If the oil mark covers less than one half of the dipstick, slowly add oil until the oil mark reaches to the top of the dipstick (or when you can see the oil coming halfway up the oil fill threads).

3. Wipe clean any oil leaks and firmly tighten the dipstick. Reinstall the oil access cover.

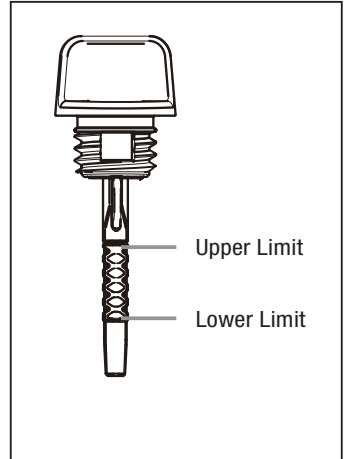
**STEP 2 - ADD/CHECK FUEL**

PETROL WARNING: Keep generator away from open flame. This generator may emit highly flammable and explosive petrol vapors, which can cause severe burns or even death if ignited. A nearby open flame can lead to explosion even if not directly in contact with petrol.

- Do not operate near open flame, heat, or any other ignition source.
- Do not smoke near the generator.
- Always operate on a firm, level surface.
- Always turn generator off before refueling. Allow generator to cool for at least 2 minutes before removing the fuel cap. Loosen cap slowly to relieve pressure in tank.
- Do not overfill fuel tank. Fuel may expand during operation. Do not fill to the top of the tank. Allow for expansion.
- Always check for spilled fuel before operating. Clean up any spilled fuel before starting.
- Empty fuel tank before storing or transporting the generator to prevent spilling.

Use **ONLY** fresh (within 30 days from purchase), lead-free petrol with a **minimum of 87 octane rating**. The generator performs best with ethanol-free petrol. **DO NOT** use petrol with over 10% ethanol. The capacity of the fuel tank is **27L** **DO NOT** mix oil with petrol.

NOTICE:

- Never use an oil/petrol mixture.
- Never use old petrol.
- Keep petrol away from sparks, open flames, pilot lights, heat and other sources of ignition.
- Avoid getting dirt or water into the fuel tank.
- Petrol can age in the tank and make starting difficult. Never store generator for more than 2 months with fuel in the tank.

To add petrol, follow these steps:

1. Make sure the generator is shut OFF and on a level surface. Unscrew the fuel cap and set it aside. The fuel cap may be tight and hard to unscrew.

2. Slowly add unleaded petrol to the fuel tank. Be careful not to overfill.

NOTE: Do not fill the fuel tank to the very top. If you do, petrol will expand and spill during use, even with the fuel cap in place.

3. Reinstall fuel cap and wipe clean any spilled petrol with a dry cloth.

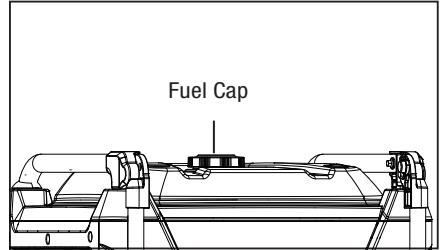

To check fuel level:

During operation, the fuel level will be displayed on the DATA CENTER of the panel, or check the fuel gauge. If the fuel level is low, refill the fuel tank before starting your generator for the next time.

STEP 3 - CONNECT THE BATTERY

⚠ WARNING: BATTERY GIVES OFF EXPLOSIVE HYDROGEN GAS.

- Keep battery away from sparks, cigarettes, or other sources of flame.
- Do not connect or disconnect battery while generator is running.
- Service or use battery only in well ventilated areas.

⚠ WARNING: Battery contains sulfuric acid. Battery acid is poisonous. Tilting the generator with the battery installed can cause battery acid to spill.

- Wear protective clothing and eye wear when servicing battery.
- Keep out of reach of children.
- If battery acid gets on your skin, wash with water immediately.
- If battery acid gets in your eyes, flush with water for at least 15 minutes and call a doctor immediately.

If battery acid is swallowed, call a doctor immediately. Drink a large amount of water or milk. Then drink milk of magnesia or vegetable oil.

The generator is shipped with the battery's negative (-) terminal disconnected to maximize safety. To start the generator using electric start, the battery must be connected.

To connect the battery:

1. Turn the battery cover knob to the unlocked position, and remove the access cover from the back panel.

2. Loosen the rubber belts and pull out the battery.

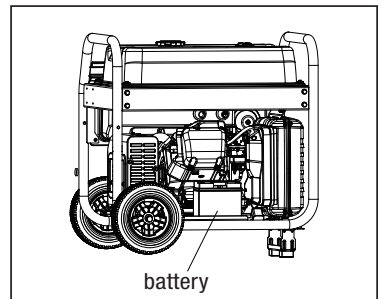

3. Remove the cover from the battery's negative (-) terminal and connect the black cable to the battery's negative (-) terminal.

The generator's positive pole has already been connected. Double check to confirm that the connection is secure.

4. Return the battery into position and use the rubber belts to fasten the battery.

5. Reinstall and secure the battery access cover.

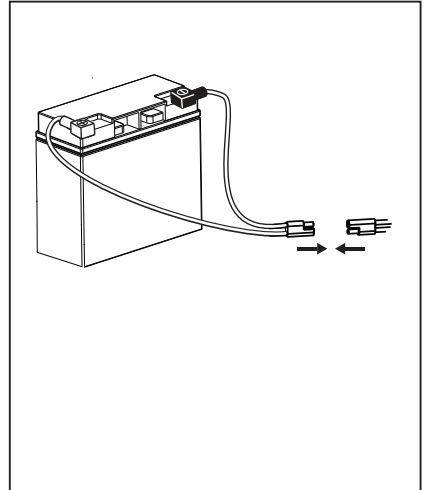

NOTICE: If you do not plan to use the generator for a long period of time, we recommend to DISCONNECT the negative battery cable from the battery to protect the battery from losing charge. After disconnecting the cable, cover the free end with an insulator such as electrical tape. You may also choose to use a trickle charger (not included) to maintain battery charge.

STEP 4 - GROUND THE GENERATOR

To reduce the risk of electric shock and to maximize safety, the generator should be properly grounded.

Ground the generator by tightening the grounding nut on the front control panel against a grounding wire. A generally acceptable grounding wire is a **4mm² (Australian stranded copper wire)**.

This grounding wire should be connected at the other end to a copper, brass, or steel grounding rod that is driven into the earth. Wire and grounding rods are not included with the generator.

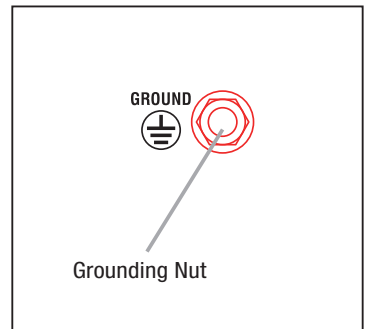

NOTE: Grounding codes can vary by location. Contact a local electrician to check the area codes.



WARNING: Failure to properly ground the generator increases your risk of electric shock.

HIGH ALTITUDE OPERATION ABOVE 915 METERS

The fuel system on this generator may be affected by operation at high altitudes. At elevations above 2438 meters, the engine may experience a decrease in performance, even with the proper altitude kit. Operating this generator may increase the engine's emissions and decrease both fuel economy and performance. Please contact your authorized service center for important information regarding these modifications.

Generator Setup

PLANNING THE POWER LOAD

Plan your power load so that you do not exceed the generator's rate capacity. To calculate the running and start wattage requirements for the devices you will be powering, follow the steps on page 10.

SET UP THE PORTABLE POWER SOURCE

This generator is designed to provide up to its max power (in watts) of electrical power. When using the generator as a portable power source, you can plug electric devices and appliances directly into the generator's electrical outlets. This generator is equipped with 2 SAA approved IP66 rate socket outlets, and 1x IP44 outlet.

Make sure you plug each electrical device/appliance into the correct generator outlet based on the device's plug configuration and voltage/amperage rating. NEVER exceed the amperage rating of an outlet. Note: You must NOT overload the generator. Overloading may cause serious damage to the generator and attached electrical devices.

SET UP AS BUILDING BACK UP

To set up as a building backup, you must arrange for a licensed electrician to connect the generator to your building's electrical system via the installation of an approved transfer switch. The transfer switch must be installed in accordance with the building electrical code and guidelines supplied by your power company.

A transfer switch does the following:

- Safely connects the generator to your building's electrical system by isolating your generator from your utility company's power lines.
- Connects your generator to a critical subset of your building's circuits that are needed for emergency power needs.

	<p>A transfer switch must be installed in order to isolate your generator from the utility power grid. If your generator is NOT properly isolated from the utility system, serious hazards will arise.</p> <p>When your generator is running, it's output will back feed into the utility power line and transformer that are normally used to provide you with power. The transformer will step up the current to the normal line voltage. An unsuspecting utility line worker working on what he thinks is a deactivated line could be electrocuted.</p> <p>If your generator is connected (running or not) when utility power is restored, your generator will be destroyed. It could also explode or cause fire.</p>
---	--

Note:

Regardless of whether you use your generator as a back-up power source connected to a building or as a portable power source, you MUST NOT overload the generator. Overloading may cause serious damage to the generator and attached electrical devices.

If your generator will be connected to your building's system, it MUST ALWAYS BE isolated from the utility power grid with an approved transfer switch installed by a licensed electrician in

EXTENSION CORDS

Extension cords may be used to power devices that are located at a distance from the generator. However, use only Australian approved outdoor-rated, grounded extension cords. Locate the generator in a convenient place and where possible, avoid long extension leads and possible damage to leads by pedestrian or vehicular traffic.

Extension leads should be heavy duty with at least 1mm of appropriate current rating and in any case, not less than 1mm cross-section of conductor and must incorporate an earthing conductor to ensure that there is no voltage difference between the generator set and any equipment powered by the generator.

The electrical continuity of the "earthing" core should be checked periodically from pin to socket to ensure continued electrical safety. Some electrical appliances, eg. portable drills, are marked "double insulated", in which case there should not be an earthing conductor in its mains lead (even though it may have a three-pin plug).



Use of under sized extension cords can cause electric shock, fire, or damage to connected devices. All extensions and appliance cords must be in good working condition and not worn, bare, frayed, or otherwise damaged.

Use of damaged electric cords can cause electric shock or fire. Note: If an extension cord becomes hot to the touch, it is overloaded or damaged and must be replaced. Maxwatt is NOT responsible for damage or injury resulting from customer use of inadequate extension cords.

SELECT A SUITABLE SITE

Before using the generator, you must select a suitable OUTDOOR location for installation and operation that meets the following criteria:

DRY LEVEL SURFACE:

The generator should be positioned on a dry, firm and level surface. Ensure that the generator sits level and will not slide or shift during operation. If applicable, block the generator's wheels to prevent sliding and shifting.



You must choose a suitable site for operating your generator to avoid equipment damage and/or injury and possible death from carbon monoxide poisoning, electric shock, or fire.

Starting Your Generator

Before starting the generator, make sure you have read and performed the steps in the “Generator Preparation” section of this manual. If you are unsure about how to perform any of the steps in this manual Please contact your authorized service center

DANGER: CARBON MONOXIDE

Using a generator indoors **CAN KILL YOU IN MINUTES**. Generator exhaust fumes contains carbon monoxide(CO).This is a poison gas you cannot see or smell. If you can smell the generator exhaust fumes, you are breathing CO. But even if you cannot smell the exhaust fumes, you could be breathing CO.

NEVER use a generator inside homes, garages, crawl spaces, or other partially enclosed areas. Deadly levels of carbon monoxide can build up in these areas. Using a fan or opening windows and doors does NOT supply enough fresh air. ONLY use a generator OUTSIDE and far away from windows, doors, and vents. These openings can pull in generator exhaust.

Even if you use a generator correctly, CO may leak into the home. ALWAYS use a battery-powered or battery-backup CO alarm in the home. If you start to feel sick, dizzy, or weak after the generator has been running, move to fresh air RIGHT AWAY. See a doctor. You may have carbon monoxide poisoning.

WARNING: DO NOT operate generator near open flame or flammable materials This generator may emit highly flammable and explosive petrol vapors, which can cause severe burns or even death if ignited. A nearby open flame can lead to explosion even if it isn't directly in contact with petrol. Do not smoke near the generator.

WARNING: This generator produces powerful voltage, which can result in electrocution.

WARNING: Do not use in rainy or wet conditions. Do not touch bare wires or receptacles (outlets). Do not allow children or non-qualified persons to operate.

WARNING: Generator should ONLY be connected to electrical devices, either directly or with an extension cord. NEVER CONNECT TO A BUILDING ELECTRICAL SYSTEM without a qualified electrician and connected to a transfer switch as a separately derived system. Such connections must comply with local electrical laws and codes. Failure to comply can create a back-feed, which may result in serious injury or death to utility workers.

To maximize safety, ALWAYS ground the generator before using it .

CAUTION: Disconnect all electrical loads from the generator before attempting to start.

Before starting the generator:

1. Verify that the generator is outside on a dry, level surface. Allow at least 1M of clearance on all sides of the generator.
2. To maximize safety, check that the generator is properly grounded (see “GROUND THE GENERATOR”).
3. Check there is sufficient level of oil in the crankcase. Add oil if necessary (see “ADD/CHECK OIL”).
4. Make sure there is sufficient level of petrol in the fuel tank. Add fuel if necessary (see “ADD/CHECK FUEL”).
5. Make sure all electrical devices are unplugged from the generator during ignition. Otherwise it will be difficult for the engine to start.

To start the generator, perform the following steps:

1. Turn the LOW IDLE MODE switch to “OFF”.
2. Turn the FUEL switch to the “ON” position.

Manual Start:

1. Turn the Fuel switch to “ON”.
2. Press the ENGINE SWITCH “ON”.
3. Pull recoil starter slowly until resistance is felt, then pull rapidly.

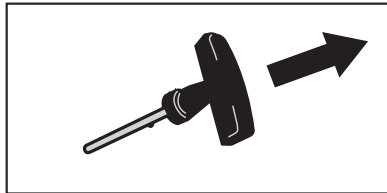
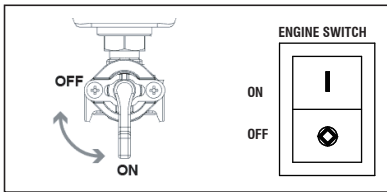

One-Button Start:

Turn the Fuel switch to “ON”, Press theENGINE SWITCH“ON”and then press One Button start.

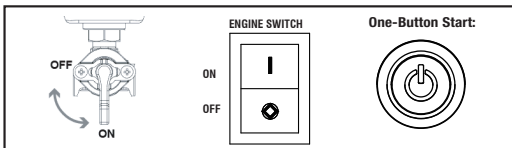

Remote Start

Turn the Fuel switch to “ON”, Press theENGINE SWITCH“ON”and then Hold down the REMOTE START switch for 3 seconds.

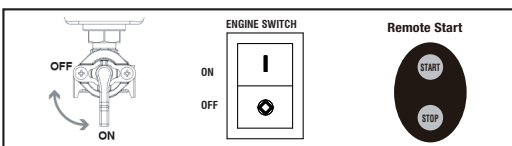

Shutting Off the Generator

CAUTION: Unplugging running devices can cause damage to the generator. Never stop the engine with electrical devices connected and running.

1. Turn off all electrical devices prior to unplugging them from the generator. Unplugging running devices can cause damage to the generator.
2. Allow generator to run at no load for a few minutes to stabilize internal temperatures.
3. press One Button "STOP" or press Remote stop "STOP", Press the ENGINE SWITCH " OFF", Turn the Fuel switch to "OFF".

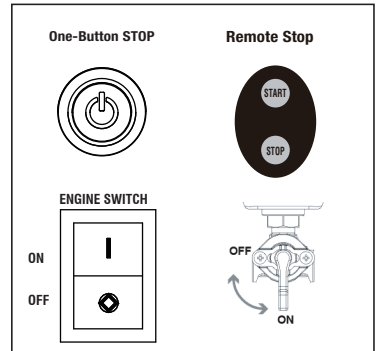

In case you are in a hurry and do not want to wait for the generator to automatically shut down, the manual shutoff feature is available. However, this method will leave stagnant fuel in the carburetor, possibly causing blockages, a shortened lifespan, and other maintenance issues. If this approach is frequently taken, make sure to drain your carburetor before any long storage periods.

1. Turn off all electrical devices prior to unplugging them from the generator. Unplugging running devices can cause damage to the generator.
2. Press the "MANUAL SHUTOFF" switch and hold it down in the "OFF" position for about 6 seconds until the engine shuts off.

CAUTION: Allowing petrol to sit in the fuel tank for long periods of time can make it difficult to start the generator in the future. NEVER store the generator for extended periods of time (over 2 months) with fuel in the fuel tank. Refer to "STORING THE GENERATOR".

Maintenance

RECOMMENDED MAINTENANCE SCHEDULE

Proper routine maintenance of the generator will help prolong the life of the machine. Please perform maintenance checks and operations according to the Maintenance Schedule. If there are any questions about the maintenance procedures listed in this manual, Please contact your authorized service center.

⚠ WARNING: Never perform maintenance operations while the generator is running. Before maintaining or servicing the generator, turn OFF the generator, disconnect all devices and allow the generator to cool down.

Recommended Maintenance Schedule		Each 8 hours or daily	Every 25 hours	Every 3 months or 50 hours	Every 6 months or 100 hours	Before Storage	As necessary
Engine Oil	Check level	x					
	Replace		x*			x	x
Air Filter	Check			x*			
	Clean			x*			
Spark Plug	Check/clean/ regap				x		
	Change					x	x
Fuel Tank	Check level	x					
	Drain					x	x
Carburetor (Auto Shutoff)	Drain					x	x
Carburetor (Manual Shutoff)		x				x	
Spark Arrestor	Check/Clean				x		
Battery	Disconnect					x	

* Clean/change more often under dusty conditions or operating under heavy load.

IMPORTANT GENERATOR MAINTENANCE TIPS:

- Drain your carburetor after each use and before storage to prevent it from clogging.
- Do not store the generator with fuel inside the tank for more than 2 months - the fuel will go bad.
- Run the generator for at least 20 minutes every month to charge the battery and maximize the generator's lifespan.

NOTE: Failure to properly maintain the generator will void the warranty.

Air Filter Maintenance

1. Remove the maintenance cover plate on the side of the unit.
2. Remove knob and air filter cover plate .
3. Remove the filter element.
4. If the filter element is dirty, wash it with warm soap and clean water and dry it.
5. Apply a layer of engine lubricant on the filter element and squeeze it out.
6. Reinstall the filter element into the air cleaner unit.
7. Reinstall the air filter cover plate .
8. Reinstall the side maintenance cover plate of the unit.

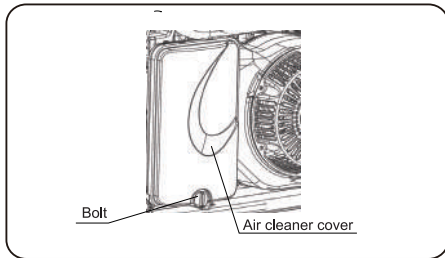

Battery Replacement

⚠ WARNING

Burn hazard. The battery contains sulfuric acid (electrolyte) which is highly corrosive and poisonous. Wear protective clothing and eye protection when working near the battery. Keep children away from the battery.

⚠ CAUTION

Battery posts, terminals contain lead and lead compounds. Wash hands after handling.

1. Unscrew the knob and remove the left maintenance cover plate .
2. Loosen the nuts and remove the battery cover.
3. Replace the battery with a new battery.
Battery Specification: 12V, lithium battery .
LxWxH:4.2x2.2x3.3 inches (107x56x85mm)
4. Put the battery back in place and fix it with nuts and battery cover plate.
5. Reinstall and fix the left maintenance cover plate.

⚠ NOTICE

Dispose of the used battery properly according to the guidelines established by your local or state government.

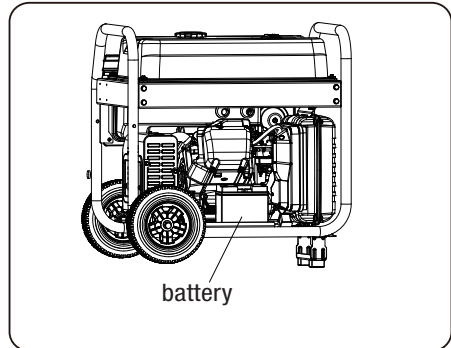

Spark Plug Maintenance

The spark plug must be properly gapped and free of deposits in order to ensure proper engine operation. To check:

1. Turn knob and remove the maintenance cover.
 2. Remove the spark plug cap .
 3. Clean any dirt from around base of spark plug.
 4. Remove spark plug using provided wrench.
 5. Inspect spark plug for damage, and clean with a wire brush before reinstalling. If insulator is cracked or chipped, spark plug should be replaced.
 6. Measure plug gap. The correct gap is 0.028-0.031 in. (0.7-0.8 mm). To widen gap, if necessary, carefully bend the ground (top) electrode. To lessen gap, gently tap ground electrode on a hard surface.
 7. Seat spark plug in position; thread in by hand to prevent cross-threading.
 8. Tighten with wrench to compress washer. If spark plug is new, use 1/2 turn to compress washer appropriate amount. If reusing old spark plug, use 1/8 to 1/4 turn for proper washer compression.
- NOTE:
An improperly tightened spark plug will become very hot and could damage the engine.
9. Reinstall the spark plug cap .

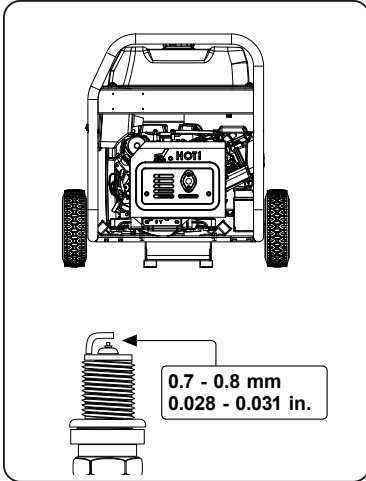

NOTE:

This product is equipped with a spark arrestor that has been evaluated by the USDA Forest Service; however, product users must comply with Federal, State, and local fire prevention regulations. Check with appropriate authorities. Contact customer service or a qualified service center to purchase a replacement spark arrestor

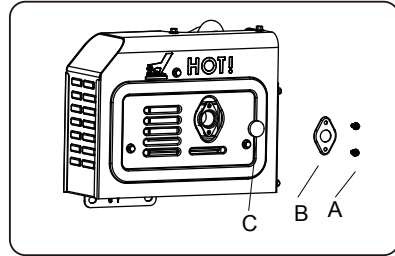

Valve Clearance

Important: Please contact Authorized Service Center for service assistance. Proper valve clearance is essential for prolonging the life of the engine. Check valve clearance per maintenance schedule.

Valve Clearance	Intake Valve	Exhaust Valve
	0.004~0.006 inch 0.1~0.15 mm	0.004~0.006 inch 0.1~0.15 mm
Torque	10-12 N·M	10-12 N·M

GENERATOR MAINTENANCE

Make certain that the generator is kept clean and stored properly. Only operate the unit on a flat, level surface in a clean, dry operating environment.

DO NOT expose the unit to extreme conditions, excessive dust, dirt, moisture or corrosive vapours.

NOTE:

DO NOT use a garden hose to clean the generator. Water can enter the generator through the cooling slots and damage the generator windings.

Use a damp cloth to clean exterior surfaces of the generator.

Use a soft bristle brush to remove dirt and oil.

Use an air compressor 25 PSI (172 kPa) to clear dirt and debris from the generator.

Inspect all air vents and cooling slots to ensure that they are clean and unobstructed.

STORAGE

It is recommended to start and run the generator for 30 minutes, every 30 days. If this is not possible, refer to below short term and long term storage.

⚠ NOTICE

Checking and adjusting valve clearance must be done when the engine is cold.

Cleaning the Spark Arrestor

1. Allow the engine to cool completely before repairing the spark arrester.
2. Loosen the bolt (A) to remove the flange pressing plate (B) and the spark arrester(C)
3. Carefully remove carbon deposits on the filter screen of spark arrester (C) with a steel wire brush.
4. If the spark arrester (C) is damaged, replace it.
5. Place the spark arrester (C) on the muffler and reinstall it with the bolts removed in step 2.

DRAINING THE FUEL TANK / CARBURETOR

To help prevent gum deposits in the fuel system, drain the fuel from the tank and carburetor before storing.

1. With the help of another person, place the generator on an elevated platform such as a table or desk.

2. Unscrew the maintenance cover knob, and remove the cover from the side panel.

To draining fuel tank:

3. Make sure that the fuel switch to turned to "ON".

To draining carburetor:

1. Make sure that the fuel switch to turned to "OFF", at this position, the fuel valve is turned OFF so that only the fuel left inside the carburetor will be drained out.

2. The carburetor can be accessed between the engine and the air filter. Locate the transparent tube from the carburetor that extends down through the base plate of the generator.

3. Prepare an approved petrol-storage container and direct the end of the drain tube into the container.

4. Open up the carburetor drain screw with a flat-head screwdriver (not included) and drain out any petrol that has built up inside the carburetor through the drain tube into the approved petrol-storage container.

5. Once the fuel has drained, tighten the drain screw with the screwdriver.

6. **NOTE:** Make sure to drain your carburetor before storing the generator for long periods of time.

7. Reinstall the service panel.

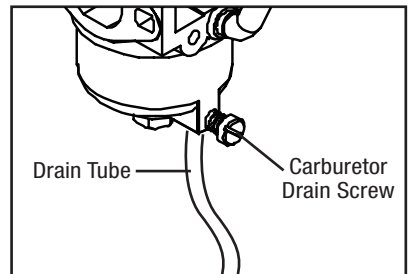
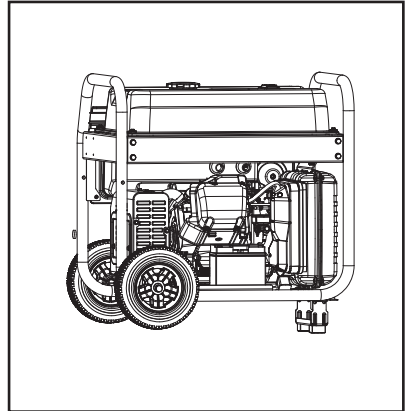

DRAINING/CHANGING OIL

Change the oil according to the Recommended Maintenance Schedule.

Change the oil MORE OFTEN if operating under heavy load or high ambient temperatures. It is also necessary to drain the oil from the crankcase if it has become contaminated with water or dirt. Changing the oil when the engine is warm allows for complete drainage.

To change engine oil:

1. With the help of another person, place the generator on an elevated platform such as table or workbench.

NOTE: To avoid possible oil spills from the carburetor bowl, drain the carburetor before draining oil.

2. Unscrew the oil access cover knob, and remove the cover from the side panel.

3. Place a suitable container underneath the generator to catch the used oil.

4. Reach under the generator and remove the black rubber seal located below the oil drain plug.

5. Remove the oil fill cap/dipstick.

6. Use a wrench to remove the oil drain plug and allow the oil to drain completely.

7. Reinstall the oil drain plug after the oil has drained.

8. Reinstall the black rubber seal.

NOTE: Never dispose of used engine oil in the trash or down a drain. Please call a local recycling center or auto garage to arrange proper oil disposal.

9. With the generator in a level position and refill with engine oil following the instructions in the Checking/Adding engine oil section previously in this manual.

10. Reinstall the oil dipstick and tighten it securely. Wipe clean any oil spillage and reinstall the oil access cover.

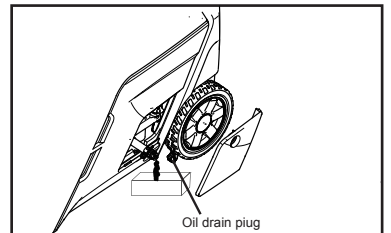
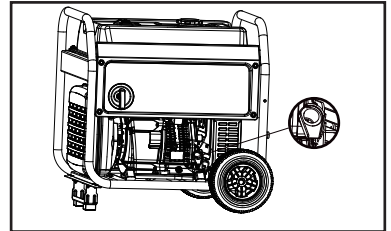

Transportation & Storage

TRANSPORTING THE GENERATOR

To prevent fuel spillage when transporting, be sure to perform the following:

1. Tighten the fuel cap and turn the vacuum relief valve to “OFF”.
2. Set the engine switch to “OFF”.
3. Drain the fuel tank if possible.
4. Keep the generator upright. Never place the generator on its side or upside down - doing so will make it difficult to start.

 **WARNING:** Avoid direct sunlight inside a vehicle. If the generator is left in an enclosed vehicle for many hours, the high temperature could cause the fuel to vaporize and result in a possible explosion.

STORING THE GENERATOR

Shut off the generator and allow the unit to cool to room temperature before storing it. NEVER place any type of storage cover on the generator while it is still hot. Do not obstruct any ventilation openings.

Follow the procedures below for properly storing your generator. We highly recommend running your generator once a month for 20 to 30 minutes. Plug in a small load in to ensure there is proper power output.

For Short Periods (30 to 60 Days):

- Drain the carburetor.
- Disconnect the negative lead from the battery.
- **Add fuel stabilizer:**

Follow the suggested portions and instructions of your preferred stabilizer. Run the engine for 15 to 20 minutes, allowing the fuel stabilizer to mix with the petrol and circulate through the carburetor, and then top off with fuel. Filling the fuel tank full reduces the amount of air in the tank and helps fight deterioration of fuel.

For Extended Periods (Over 60 Days):

- Disconnect the negative lead from the battery.
- Drain the fuel tank and carburetor (see “DRAINING THE FUEL TANK”). NEVER store generator with fuel in the tank for more than two months.
- Change the engine oil (see “CHANGING OIL”).

 **WARNING:** Store the generator upright in a cool and dry location, away from sources of heat, open flames, sparks or pilot lights.

PRODUCT DISPOSAL

Do not dispose of used generator or parts with your household waste. This product contains electrical or electronic components that should be recycled. Please take this product to your local recycling facility for responsible disposal to minimize its environmental impact.

Do not dispose of used oil or fuel in the trash or down a drain. Please contact your local recycling center or auto garage to arrange proper oil/fuel disposal.

Troubleshooting Guide

ENGINE WILL NOT START

Possible Cause	Solution
Battery not charged.	Charge battery.
Engine switch is in the OFF position.	Turn engine switch to the ON position.
No fuel.	Fill fuel tank.
Stale petrol or water in petrol.	Drain entire system and refill with fresh fuel.
Engine oil level is low.	Engine is equipped with Low Oil Shutoff. If engine oil level is low, it must be filled before unit will start. Check engine oil level and fill, if necessary.
Fuel-switch is in OFF position.	Turn fuel-switch to the ON position.
Spark plug faulty, fouled, or improperly gapped.	Replace spark plug.
Engine stored without treating or draining petrol, or refueled with bad petrol.	Drain fuel. Refuel with fresh petrol.
Dirty fuel filter.	Replace fuel filter or contact a qualified service center.

ENGINE LACKS POWER.

Possible Cause	Solution
Dirty air filter.	Check air filter element. Clean or replace as needed.
Engine stored without treating or draining petrol, or refueled with bad petrol.	Drain fuel. Refuel with fresh petrol. If problem continues, contact a qualified service center.

AC RECEPTACLE DOES NOT WORK.

Possible Cause	Solution
OUTPUT indicator is OFF, and OVERLOAD indicator is ON.	Check AC load. Stop and restart the engine. Check the cooling air inlet. Stop and restart the engine.
AC Circuit protector(s) tripped.	Check AC load and reset AC circuit protector(s)
GFCI system activated.	Reset the GFCI.
Item plugged in is defective.	Try a different item.

If problem persists after trying the above solutions, contact your nearest authorized service center for assistance.

Warranty

As part of an on-going commitment to excellence in product support, Euroquip offers a comprehensive product warranty program.

1. THIS WARRANTY:

The benefits provided to the consumer in this warranty are in addition to other rights and remedies of a consumer under the New Zealand Consumer Guarantees Act 1993 and any other laws in relation to the products to which this warranty relates. This warranty:

- Covers the product against faulty materials or workmanship; and
- Covers the replacement of parts, the repair labour used, a refund of the price of the product or replacement of the machine, or other compensation for the remainder of the warranty period.

This product warranty is only applicable to the original purchaser of the machine and only purchases made from Euroquip Authorized Retailers.

2) WARRANTY PERIODS:

Commercial Warranty*: 2 Years (24 months)
Domestic Warranty* : 4 Years (48 months)

Or

1000 hours of operation – whichever occurs first.

Domestic Warranty applies to domestic use of the product: Personal, residential, or household use only. Commercial Warranty applies to commercial or business use of the product: All uses other than domestic use, including use for income-producing (including farming) or rental purposes.

*These GT Power Warranty periods are for products that are:

- Purchased from a New Zealand GT Power Dealer after 01/06/23
- Serviced by a GT Power Dealer in accordance with the GT Power service schedule, using genuine parts and the correct grade of oil (proof required)
- Meeting all other warranty requirements

NOTE: These warranty conditions apply to New Zealand only.

Euroquip warrants each new GT Power machine free from defect in material and workmanship under normal use and routine servicing, for the warranty periods specified. Conditional to the limitations and exclusions list below. The warranty period begins when the product is purchased by the end user. Warranty is not transferrable and is only claimable by the original purchaser.

Proof of purchase documentation with product serial number must be provided. If it has been lost and Euroquip does not have a record of the purchaser's details, the warranty period shall be calculated from the appropriate dealer wholesale sale date.

The purchaser must keep a record of all service and maintenance history as proof of servicing history. This may be requested when assessing any future warranty claims. The decision that an issue with a product qualifies as a warranty claim is made at the sole jurisdiction of Euroquip.

No costs incurred will be considered under warranty if repairs or maintenance are carried out by any party other than a Euroquip Approved Service Agent, unless with prior consent in writing from Euroquip.

It is the full responsibility of the purchaser to deliver the product under warranty to the nearest relevant service agent or product reseller. Warranty does not cover transportation costs including call outs, mileage and freight costs.

Customers are responsible for the care and cleaning of their product prior to sending it to our service centre. Any product being sent us must be thoroughly cleaned. Depending on what the product has come into contact with, it could pose an Occupational/ Work Health and Safety risk for our staff and or/service agents to inspect, repair or service a product that has come into contact with a hazardous substance. If we are asked to inspect, repair or service a product that has come into contact with a hazardous substance such as chemicals, asbestos or silica dust, we may not be able to inspect, service or repair the product. If this is the case, we will inform the purchaser and the product will be returned.

If a product is repaired under warranty, parts and labour required for the repair will be supplied at no charge. All defective parts replaced under warranty become property of Euroquip. Consumable items such as, but not limited to, oils, coolants, filter and spark plugs shall be the responsibility of the owner. Warranty assessment and repair will be scheduled and executed according to the normal work flow at the service location and depending on the availability of suitable replacement parts.

This warranty policy is an additional benefit and does not supersede the legal rights of any customer, reseller or service agent.

Should any issue be found to be a combination of a warranty failure and a non-warranty issue such as incorrect charging techniques, the repair cost component to rectify and repair the non-warranty failure is the **customer's** full responsibility.

3) EXCLUSIONS:

- Warranty does not cover parts that are subject to wear and tear from usage and/or damage which results from neglect of periodic maintenance.
- Evidence must be provided that the product has been maintained and serviced suitably for a claim to be considered under warranty.
- Batteries supplied with your product are warranted against defect for 3 months and does not include lack of charge due to non-use. Consumable items such as, but not limited to, oils, coolants, filters, spark plugs and batteries shall be the responsibility of the purchaser.
- Failure caused by incorrect operation of the product as specified in the manual either intentionally or by error.
- Lack of proper care and maintenance of the product.
- Any damage which results from unavoidable natural disasters, fire, collision, theft, etc.
- Any normal wear or deterioration, such as that of sliding or rotating parts caused under normal operating conditions.
- Any damage that results from misuse or use beyond the imitations of the products intended purpose (such as overloading or use under abnormal conditions).
- External circumstances such as product deterioration or corrosion due to environmental conditions like heat, cold, salt spray, sand or due to the passage of time
- Normal phenomena such as noise, vibration or oil seepage which are considered by Euroquip as not affecting the quality, function or performance of the product.
- Any damage due to improper storage or transport.
- Consumable replacement items: Spark plugs, contact points, shear pins, fuel strainers, oil filter elements, air cleaner elements, brake shoes or pads, clutch components, fuses, motor brushes, gaskets, tube or hoses, belts, cutting blades, light bulbs, serviceable bearings. Petroleum and others fluids: Oil, grease, battery electrolyte, and radiator coolant. Other items specified by Euroquip.
- Periodical maintenance items such as cleaning, inspection and adjustments.
- Contaminated fuel
- Modifications or installations of other products to the product
- Damage that results from the use of non-genuine parts, lubricant or fluid not approved by Euroquip
- Any repair and/or adjustment to correct improper or poor quality work previously performed.
- Attempted repair/ service by a party other than an Approved Service Agent, or any repair undertaken prior to approval of warranty be Euroquip is not covered under warranty.
- Warranty does not cover pre delivery service and adjustment, or failure that may occur as a result of lack of/ incorrect pre delivery service and adjustment. Warranty does not cover any incidental, indirect or consequential loss, damage, personal injury, or expense that may result from any defect, failure, malfunction, or misuse of a product.
- Any product that is found to have come into contact with hazardous substances such as chemicals, asbestos or silica dust and NOT been industrially cleaned prior to servicing.

4) HOW TO CLAIM WARRANTY:

In the event you are faced with a manufacturing fault with your GT Power product, you can claim a repair or part replacement under warranty if the following conditions are fulfilled:

- The problem is related to production quality or specifications of the machine
- The machine is within the warranty period outlined in schedule
- The issue does not fall within the warranty exclusions listed

If the criteria above is met, and you would like to request a warranty, then please go online to <https://www.euroquip.co.nz/Service-Request-End-User> and log your warranty claim.



GT10000Ei ELECTRIC START INVERTER GENERATOR



GT10000Ei ELECTRIC START INVERTER GENERATOR



GT10000Ei ELECTRIC START INVERTER GENERATOR



Congratulations on your new GT POWER product. We are proud to have you as our customer and will strive to provide you with the best service and reliability in the industry. This product is backed by our extensive warranty and world-wide service network. To locate your nearest distributor or service agency visit www.gtpower.co.nz, or email us at sales@euroquip.co.nz